



UL INTERNATIONAL (UK) LTD
 Womersley House, Building C,
 The Guildway,
 Old Portsmouth Road,
 Guildford. GU3 1LR.
 United Kingdom.



designated according to Article 29 of the Regulation (EU) No 305/2011 and member of EOTA (European Organisation for Technical Assessment, www.eota.eu)

European Technical Assessment

**ETA 18/0412
of 30/05/2018**

Technical Assessment Body issuing the ETA and designated according to Article 29 of the Regulation (EU) No 305/2011: UL International (UK) Ltd

Trade name of the construction product

EZ-Path® Fire-Rated Pathway (Series 33 and Series 44+)

Product family to which the construction product belongs

Fire Stopping and Sealing Product:
 • Penetration Seals

Manufacturer

Legrand
 BP 30076
 87002 Limoges CEDEX France

Manufacturing plant(s)

C/003, C/004, C006

This European Technical Assessment contains

25 pages including 2 Annexes which form an integral part of this assessment.

This European Technical Assessment is issued in accordance with regulation (EU) No 305/2011, on the basis of

EAD 350454-00-1104, September 2017

Translations of this European Technical Assessment in other languages shall fully correspond to the original issued document and should be identified as such.

Communication of this European Technical Assessment, including transmission by electronic means, shall be in full. However, partial reproduction may be made, with the written consent of the issuing Technical Assessment Body. Any partial reproduction has to be identified as such.

Table of Contents

1	Technical description of the product	3
2	Specification of the intended uses of the product in accordance with the applicable European Assessment Document (Hereinafter EAD): EAD 350454-00-1104.....	4
3	Performance of the product and references to the methods used for its assessment	5
4	ASSESSMENT AND VERIFICATION OF CONSTANCY OF PERFORMANCE (HEREINAFTER AVCP) SYSTEM APPLIED, WITH REFERENCE TO ITS LEGAL BASE.....	5
5	Technical details necessary for the implementation of the AVCP system, as provided for in the applicable EAD	6
6	Issued on:.....	7
ANNEX A – Manufacturer installation instructions.....		8
A.1	Abbreviations.....	8
A.2	Seal Types	9
A.3	Penetration Services	19
A.4	Opening sizes.....	20
A.4.1	Wall.....	20
A.4.2	Floor.....	22
ANNEX B – Resistance to Fire Classifications		23
B.1	EZ-Path® Fire Rated Pathway Series 33	23
B.2	EZ-Path® Fire Rated Pathway Series 44+ in flexible and rigid wall	24
B.3	EZ-Path® Fire Rated Pathway Series 44+ in rigid floor	25

SPECIFIC PARTS OF THE EUROPEAN TECHNICAL ASSESSMENT

1 Technical description of the product

1.1 General

- 1) The EZ-Path® Fire-Rated Pathway is a cable management firestop device (cable box), designed in two sizes (Series 33 and Series 44+) and can be installed as a single pathway or as multiple ganged pathways. EZ-Path® Fire-Rated Pathway Series 44+ can be ordered as reference EZD44T or EZD44T2. EZ-Path® Fire-Rated Pathway Series 33 can be ordered as EZD33T or EZD33T2. The EZ-Path Fire-Rated Pathway consist of an enclosed powder-coated galvanized steel box assembly.
- 2) EZ-Path® Fire-Rated Pathways and the device extensions internally incorporate intumescent foam pads on top and bottom, which expands upon heating to close the pathway around services to prevent the passage of fire. This intumescent foam may also be used as a wall plate gasket. It expands upon heating to close any gap between the pathway and periphery of the opening.
- 3) EZ-Path® Fire-Rated Pathways Series 44+ (EZD44T) and Series 33 (EZD33T) internally incorporates on each side an intumescent cellulose based sheet. The pathways EZD44T2 and EZD33T2 do not incorporate these intumescent cellulose based sheets. The intumescent cellulose based sheet can be used as a wall plate gasket (EZ-Path® Fire-Rated Pathways Series 44+). The intumescent sheet can be wrapped around the exposed surfaces of the EZ-Path Fire- Rated Pathway (Series 33 and 44+) when provided in the corresponding plate kit. This intumescent sheet is installed within the STI SpecSeal® CS Composite Sheet.
- 4) EZ-Path® Fire-Rated Pathway solution may incorporate an intumescent wrap strip used as a wall plate gasket for EZ-Path Fire-Rated Pathway Series 44+. It expands upon heating to close any gap between the pathway and periphery of the opening.
- 5) EZ-Path Fire -rated Pathway can be used as blank (empty) up to 100% visually full of services
- 6) The applicant has submitted a written declaration that EZ-Path® Fire-Rated Pathway does not contain substances which have to be classified as dangerous according to Directive 67/548/EEC and Regulation (EC) No 1272/2008 and listed in the "Indicative list on dangerous substances" of the EGDS - taking into account the installation conditions of the construction product and the release scenarios resulting from there.

In addition to the specific clauses relating to dangerous substances contained in this European Technical Assessment, there may be other requirements applicable to the products falling within its scope (e.g. transposed European legislation and national laws, regulations and administrative provisions). In order to meet the provisions of the Construction Products Regulation, these requirements need also to be complied with, when and where they apply.

- 7) The use category of EZ-Path® Fire-Rated Pathway in relation to BWR 3 (Hygiene, health and environment) is IA1, S/W3

1.2 Additional components

- 1) EZ-Path® Fire-Rated Pathway can be installed as a single pathway or as multiple ganged pathways utilizing the appropriate wall or floor plate kits.
- 2) EZ-Path® Fire-Rated Pathway can be installed in association with the device extension EZD33E or EZD44ES in thicker barriers. Device extension is used to extend EZ-Path Pathway from both surfaces of wall or floor. Extension device can be used in association with every wall or floor kits.

- 3) EZ-Path® Fire-Rated Pathway can be installed in association with STI SpecSeal® CS Composite Sheet in flexible and rigid walls. STI SpecSeal® CS Composite Sheet is made of intumescent cellulose based sheet encapsulated between a galvanized steel sheet, steel wire mesh and aluminum foil.
- 4) EZ-Path® Fire-Rated Pathway can be installed in association Rockwool Firepro® Ablative Coated Batt and Rockwool FirePro® Intumescent Acoustic Sealant in flexible and rigid walls.
- 5) EZ-Path® Fire-Rated Pathway can be installed in association with Rockwool Firepro® Ablative Coated Batt and Rockwool FirePro® Firestop Compound in rigid floors.
- 6) The components Rockwool Firepro® Ablative Coated Batt (ETA 15/0337), Rockwool FirePro® Intumescent Acoustic and Rockwool FirePro® Firestop Compound are not assessed within this document except for the resistance to fire classifications given in Annex B. Rockwool Ltd should be consulted with respect to the essential characteristics of these products, as required.

2 Specification of the intended uses of the product in accordance with the applicable European Assessment Document (Hereinafter EAD): EAD 350454-00-1104

Detailed information and data is given in Annex A.

- 1) The intended use of EZ-Path Fire-Rated Pathway is to reinstate the fire resistance performance of flexible wall constructions, rigid walls and rigid floors where they are penetrated by services or where services have not been installed yet. Services can be retrofitted or removed after installation.
- 2) The specific elements of construction that the system EZ-Path® Fire-Rated Pathway may be used to provide a penetration seal in, are as follows:
 - a. Flexible walls: The wall must have a minimum thickness of 100 mm and comprise steel studs or timber studs lined on both faces with minimum 2 layers of 12.5 mm thick boards.
 - b. Rigid walls: The wall must have a minimum thickness of 100 mm and comprise concrete, aerated concrete or masonry, with a minimum density of 650 kg/m³.
 - c. Rigid floors: The floor must have a minimum thickness of 150 mm and comprise concrete, aerated concrete or masonry, with a minimum density of 650 kg/m³.

The supporting construction must be classified in accordance with EN 13501-2 for the required fire resistance period.

- 3) The System EZ-Path® Fire-Rated Pathway may be used to provide a penetration seal with cables, wires and tubes (for details see Annex A).
- 4) Services shall be supported at maximum 300 mm from both faces of the wall.
- 5) The provisions made in this European Technical Assessment are based on an assumed working life of the EZ-Path® Fire-Rated Pathway of 10 years, provided that the conditions laid down in sections 4.2/5.1/5.2 for the packaging/transport/ storage/installation/use/repair are met. The indications given on the working life cannot be interpreted as a guarantee given by the producer, but are to be regarded only as a means for choosing the right products in relation to the expected economically reasonable working life of the works.
- 6) Type Y₂: Intended for use at temperatures below 0°C, but with no exposure to rain nor UV. Includes lower classes.

3 Performance of the product and references to the methods used for its assessment

Product-type: Cable box		Intended use: Penetration Seal
Assessment method	Essential characteristic	Product performance
BWR 2 Safety in case of fire		
EN 13501-1	Reaction to fire	Class 'E'
EN 13501-2	Resistance to fire	Annex A & B
BWR 3 Hygiene, health and environment		
EN 1026	Air permeability	No performance determined
EAD 350454-00-1104, Annex C	Water permeability	No performance determined
Declaration of manufacturer & EN 16516	Content, emission and/or release of dangerous substances	Use categories: IA1, S/W3 Declaration of manufacturer
BWR 4 Safety in use		
EOTA TR 001:2003	Mechanical resistance and stability	No performance determined
EOTA TR 001:2003	Resistance to impact/movement	
EOTA TR 001:2003	Adhesion	
EAD 350454-00-1104, Clause 2.2.9	Durability	Y ₂
BWR 5 Protection against noise		
EN 10140-1,2,4,5/ EN ISO 717-1	Airborne sound insulation	No performance determined
BWR 6 Energy economy and heat retention		
EN 12664, EN 12667, EN 12939, EN ISO 8990, EN ISO 6946, EN ISO 14683, EN ISO 10211, EN ISO 10456	Thermal properties	No performance determined
EN ISO 12572, EN 12086, EN ISO 10456	Water vapour permeability	No performance determined

4 ASSESSMENT AND VERIFICATION OF CONSTANCY OF PERFORMANCE (HEREINAFTER AVCP) SYSTEM APPLIED, WITH REFERENCE TO ITS LEGAL BASE

According to the decision 1999/454/EC – Commission Decision of date 22nd June 1999 on the procedure for attesting the conformity of construction products pursuant to Article 20(2) of Council Directive 89/106/EEC as regards fire stopping, fire sealing and fire protective products, published in the Official Journal of the European Union (OJEU) L178/52 of 14/07/1999, see <http://eur-lex.europa.eu/JOIndex.do>) of the

European Commission¹, as amended, the system(s) of assessment and verification of constancy of performance (see Annex V to Regulation (EU) No 305/2011) given in the following table(s) applies (apply).

Product(s)	Intended use(s)	Level(s) or class(es)	System(s)
Fire stopping and Fire Sealing Products	For fire compartmentation and/or fire protection or fire performance	Any	1

5 Technical details necessary for the implementation of the AVCP system, as provided for in the applicable EAD

Tasks of the manufacturer:

Factory production control

The manufacturer shall exercise permanent internal control of production. All the elements, requirements and provisions adopted by the manufacturer shall be documented in a systematic manner in the form of written policies and procedures, including records of results performed. This production control system shall ensure that the product is in conformity with this European technical Assessment.

The manufacturer may only use initial / raw / constituent materials stated in the technical documentation of this European Technical Assessment.

The factory production control shall be in accordance with the Control Plan of 25th April 2018 relating to the European Technical Assessment ETA 18/0412 issued on 30/05/2018 which is part of the technical documentation of this European Technical Assessment. The "Control Plan" is laid down in the context of the factory production control system operated by the manufacturer and deposited at UL International (UK) Ltd.

The results of factory production control shall be recorded and evaluated in accordance with the provisions of the Control Plan.

¹ Official Journal of the European Communities L178/52 of 14/7/1999

Other tasks of the manufacturer

Additional information

The manufacturer shall provide a technical data sheet and an installation instruction with the following minimum information:

(a) Technical data sheet:

- Field of application:
- Building elements for which the linear joint seal or penetration seal is suitable, type and properties of the building elements like minimum thickness, density, and - in case of lightweight constructions – the construction requirements.
- Limits in size, minimum thickness etc. of the joint or penetration seal
- Construction of the linear joint seal or penetration seal including the necessary components and additional products (e.g. backfilling material) with clear indication whether they are generic or specific.
- Services which the penetration seal is suitable, type and properties of the services like material, diameter, thickness etc. in case of pipes including insulation materials; necessary/allowed supports/fixings (e.g. cable trays)

(b) Installation instruction:

- Steps to be followed
- Procedure in case of retrofitting
- Stipulations on maintenance, repair and replacement

6 Issued on:

30th May 2018

Report by:



C. Johnson
Staff Engineer
Building and Life Safety Technologies

Reviewed by:



C. W. Miles
Business Manager – Europe & Latin America
Building and Life Safety Technologies

For and on behalf of UL International (UK) Ltd.

ANNEX A – Manufacturer installation instructions

A.1 Abbreviations

A1	EZD33T or EZD33T2, EZ-Path® Fire Rated Pathway Series 33
A2	EZD44T or EZD44T2, EZ-Path® Fire Rated Pathway Series 44+
B1	Steel plate kits / steel brackets
B2	Gasket : Intumescent cellulose sheet
B3	Gasket : Intumescent foam
B4	Gasket : Intumescent wrap strip
B5	Gasket : Ceramic fiber
B6	Gasket : Fiberglass
B7	Steel clip
C	STI SpecSeal® Composite Sheet
D1	Rockwool Firepro® Ablative Coated Batts
D2	Rockwool FirePro® Intumescent Acoustic Sealant
D3	Rockwool FirePro® Firestop Compound
E	Stone wool (min 45 kg/m ³ or 100 kg/m ³)
F	Regular construction mortar
G1	Flexible wall
G2	Rigid wall
G3	Rigid floor
H	Cables / Conduits
I	Steel cable support cover

A.2 Seal Types

Seal Type	Penetration Seal	Number of EZ-Path® Pathways	EZ-Path® plate kits	Wall	
				Flexible	Rigid
1	EZ-Path® Series 33	1 up to 2 grouted ganged pathways	-	-	X
2		1 up to 7 ganged pathways	EZP133CWT EZP233WT EZP333WT EZP433WT EZP733WT	X	X
3	EZ-Path® Series 44+	1 up to 5 grouted ganged pathways	-	-	X
4		Single Pathway	EZP144WE	X	X
5			EZP144RSE	X	X
6			EZP144WT	X	X
7		1 up to 5 ganged pathways	EZP544WE	X	X
8			EZP544WT	X	X
9	EZ-Path® Series 44+ + Rockwool Firepro® Ablative Coated Batts + Rockwool FirePro® Intumescent Acoustic Sealant	1 up to 5 ganged pathways	EZP544WE	X	X
10	EZ-Path® Series 44+ + STI SpecSeal® Composite Sheet	1 up to 10 ganged pathways	EZP544WE	X	X

Seal Type	Penetration Seal	Number of EZ-Path® Pathways	EZ-Path® plate kits	Rigid floor
11	EZ-Path® Series 33	Single pathway	EZP133KT	X
12	EZ-Path® Series 44+	Single pathway	EZP144MBE	X
13		Single pathway	EZG144T	X
14		2 up to 5 ganged pathways	EZP544MBE	X
15		4 ganged pathways	EZG444T	X
16		8 ganged pathways	EZG844T	X
17	EZ-Path® Series 44+ + Rockwool Firepro® Ablative Coated Batts + Rockwool FirePro® Firestop Compound	1 up to 5 ganged pathways	EZP544MBE	X

Systems installation instructions

Step 1:

- EZ-Path® Fire Rated Pathways (Series 33 and Series 44+) are installed in walls and floors secured by various plates or brackets. Pathways can be grouted in rigid wall. Refer to installation instructions for additional information regarding the selection of the appropriate kits.
- When required, plates shall be secured to wall or floor using the appropriate type of screws if necessary.
- At the option to the installer, pathways may be earth grounded using ground screws delivered in plate kits.

Step 2:

- After installation of EZ-Path® Fire Rated Pathways into wall or floor, intumescent paper to be wrapped around EZ-Path Fire-Rated Pathways and maintained in position using steel clips supplied together within plate kits. Intumescent paper to be wrapped around pathways on both sides of wall and top side of floor. For grouted pathways, no additional intumescent paper needs to be wrapped.
- For Seal Types 1, 3, 11, 12 and 14 annular space into opening to be filled with regular construction mortar.

Step 3 (optional, see Annex Resistance to Fire Classification for more details)

- A cable tray cover with an intumescent paper sheet inside the cable tray may have to be installed flush with edge of EZ-Path Fire-Rated Pathways on both sides of wall or top side of floor to reach the required resistance to fire classification (see Annex B). A min 300mm long cable tray cover on both sides of wall or a min 400mm long cable tray cover on top side of floor may have to be installed. Intumescent paper sheet is supplied within plate and grid kits.

Seal Type 1

One or two EZ-Path® Pathways Series 33 grouted in rigid wall using regular construction mortar to fill annular space.

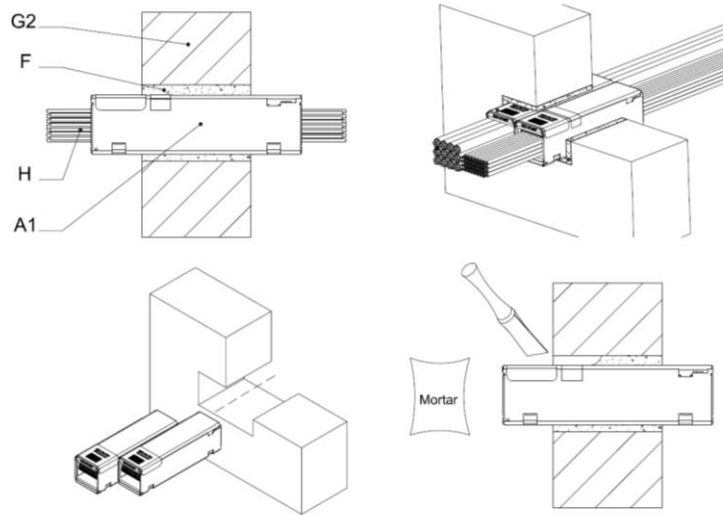

Seal Type 2

Single up to seven ganged EZ-Path® Pathways Series 33 secured to flexible or rigid wall using the corresponding plate kits.

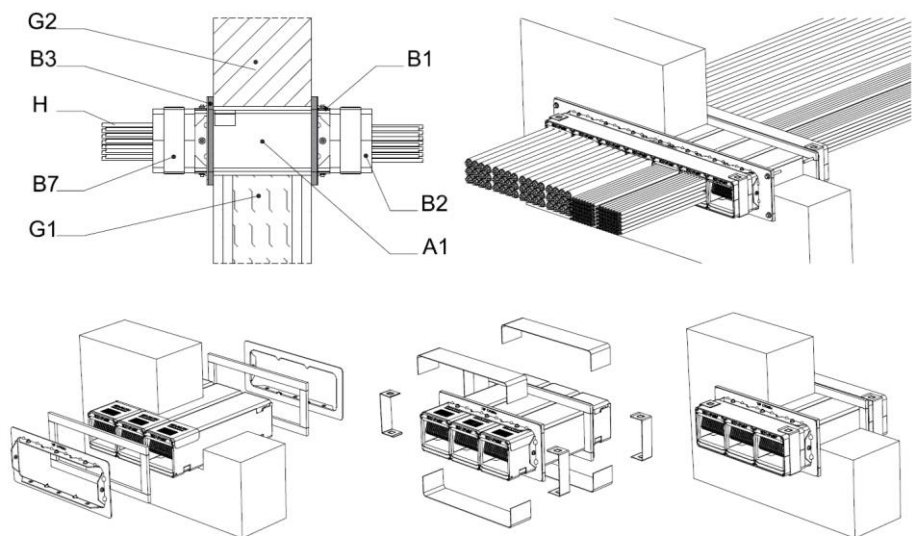

Seal Type 3

Single up to five ganged EZ-Path® Pathways Series 44+ grouted in rigid wall using regular construction mortar to fill annular space.

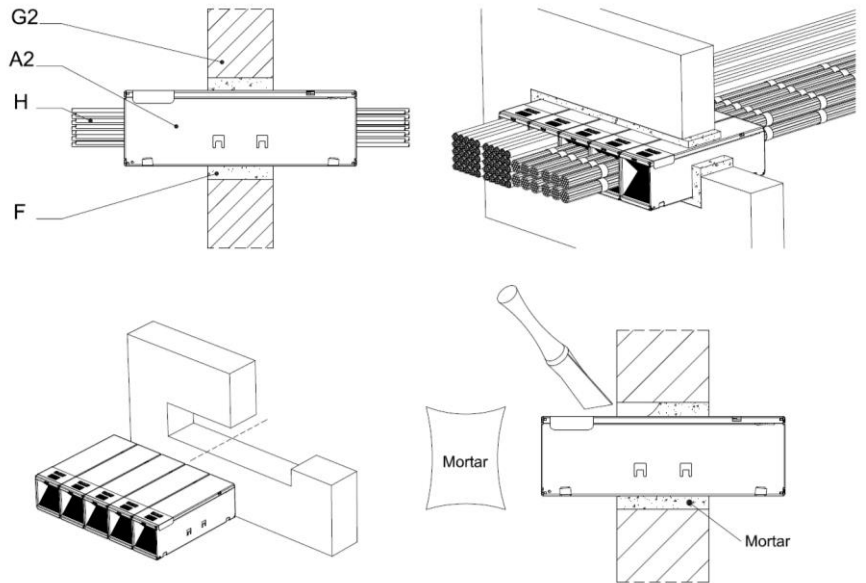

Seal Type 4

Single EZ-Path® Pathway Series 44+ secured to rigid or flexible wall using plate kit E郑144WE.

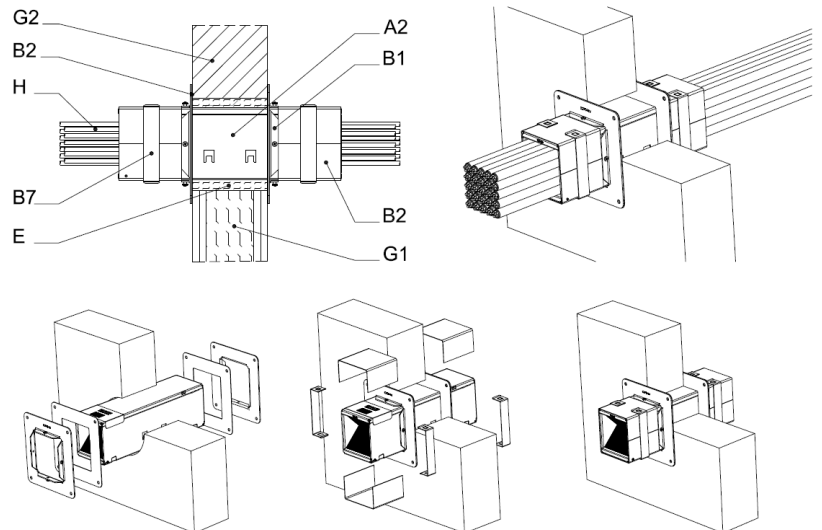

Seal Type 5

Single EZ-Path® Pathway Series 44+ secured to rigid or flexible wall using retrofit plate kit E郑144RSE.

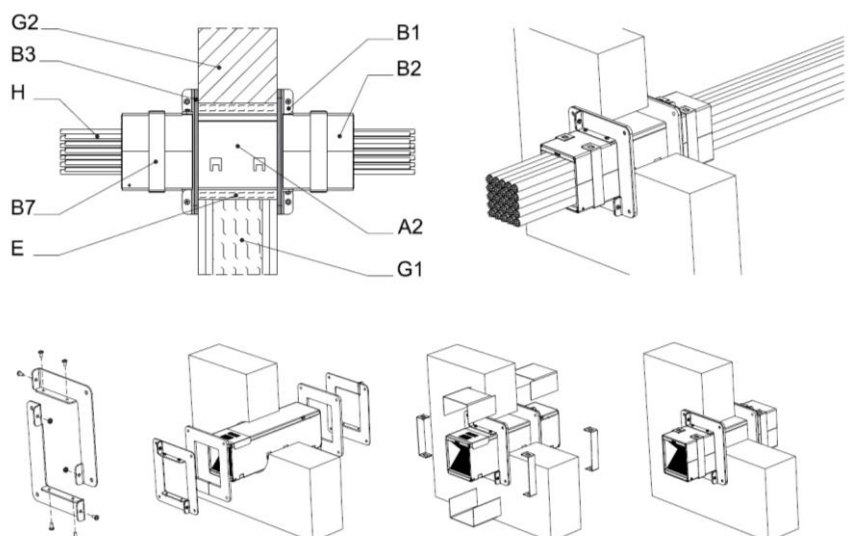

Seal Type 6

Single EZ-Path® Pathway Series 44+ secured to rigid or flexible wall using plate kit EZP144WT

Please refer to the Annex B "Resistance to Fire Classification" when cable tray in association with cable tray cover (I) and intumescent paper sheet (B2) is required.

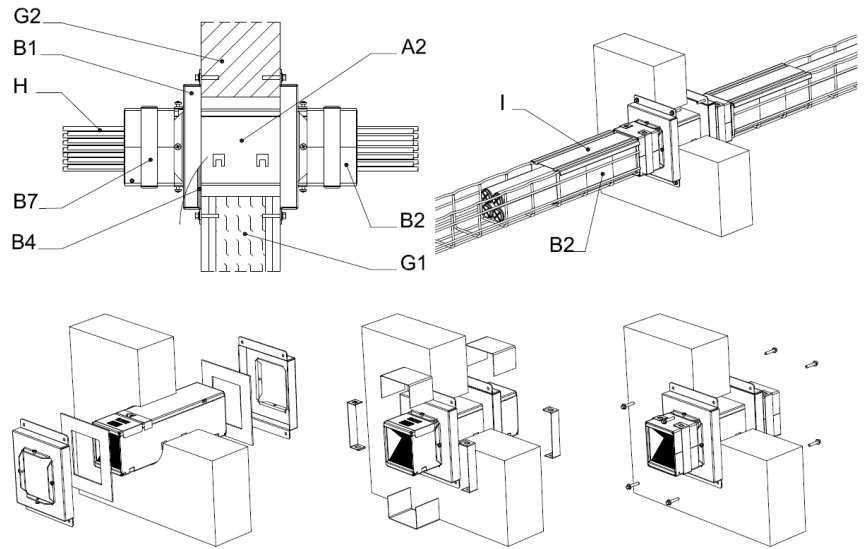

Seal Type 7

Single up to five EZ-Path® Pathways Series 44+ secured to rigid or flexible wall using plate kit EZP544WE

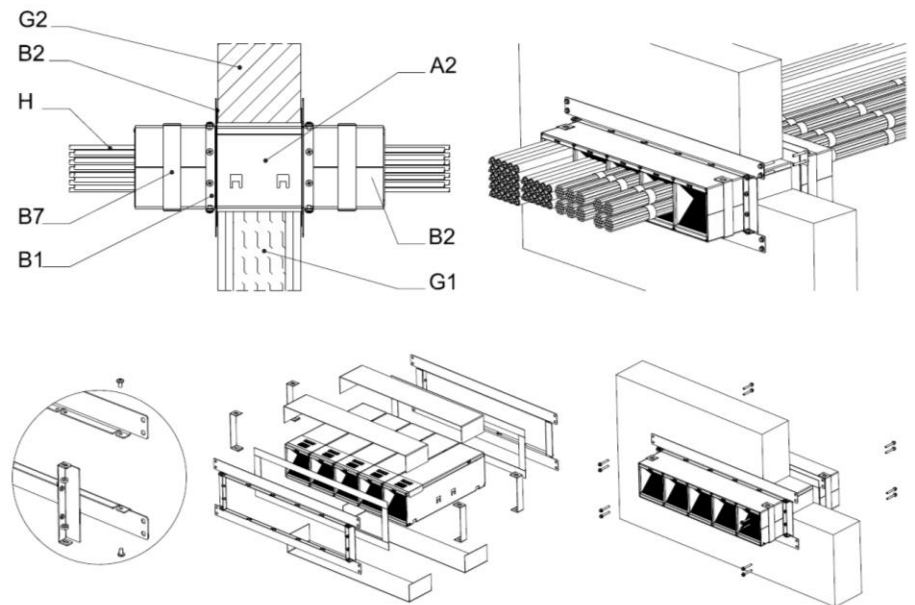

Seal Type 8

Single up to five EZ-Path® Pathways Series 44+ secured to rigid or flexible wall using plate kit EZP544WT

Please refer to the Annex "Resistance to Fire Classification" when cable tray in association with cable tray cover (I) and intumescent paper sheet (B2) is required.

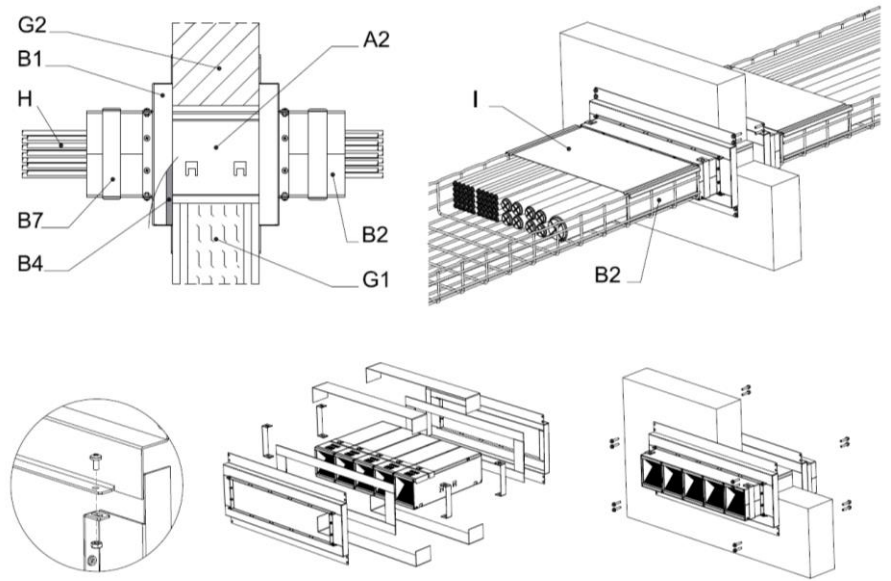

Seal Type 9

Single up to five EZ-Path® Pathways Series 44+ secured to rigid or flexible wall using plate kit EZP544WE in association with two min 50mm thick Rockwool Firepro® Ablative Coated Batts and Rockwool FirePro® Intumescent Acoustic Sealant applied onto the perimeter of opening between wall and coated batts.

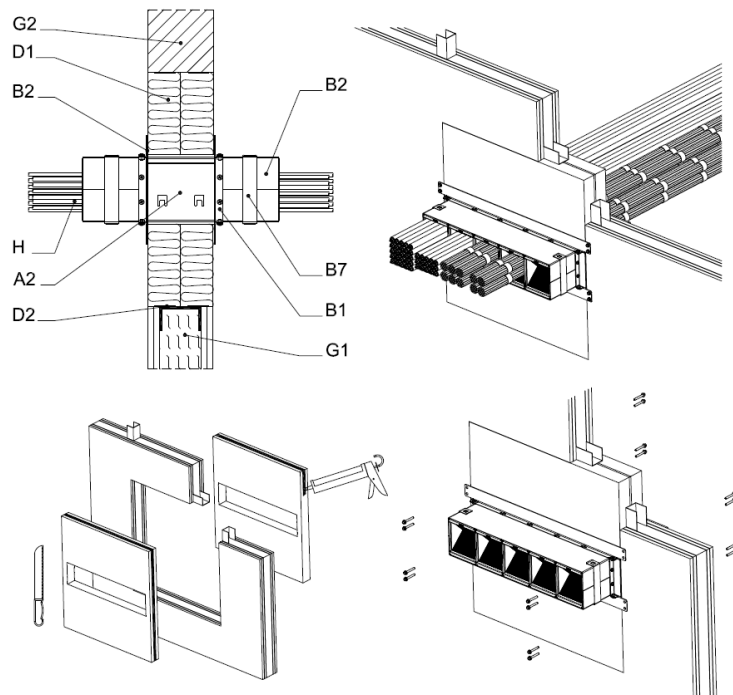

Seal Type 10

Single up to ten EZ-Path® Pathways Series 44+ secured to rigid or flexible wall using plate kit EZP544WE in association with two STI SpecSeal® Composite Sheets installed on both sides of wall. Space between composite sheets filled with mineral wool batt insulation. Please refer to the Annex B "Resistance to Fire Classification".

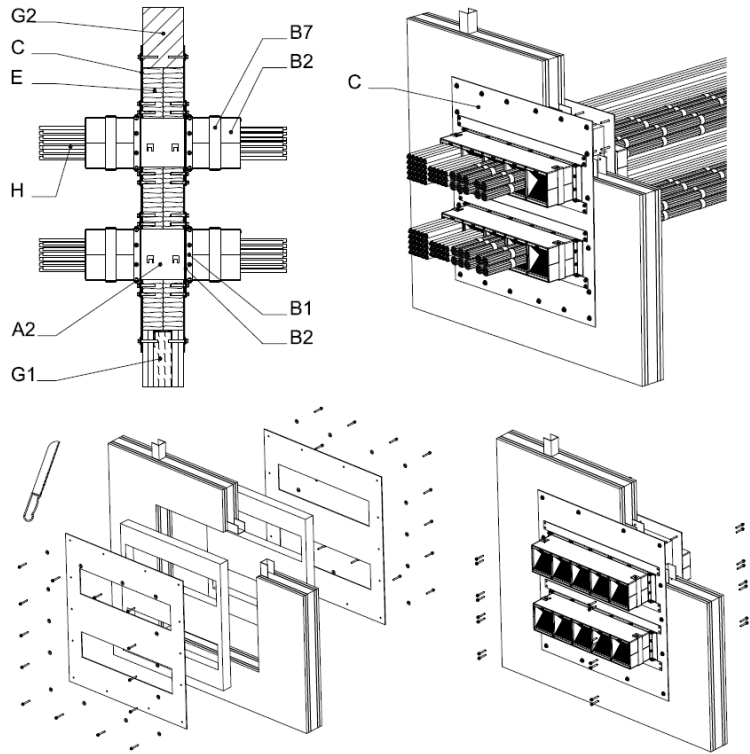

Seal Type 11

Single EZ-Path® Pathway Series 33 secured to rigid floor using plate kit EZP133KT. Annular space filled with regular construction mortar.

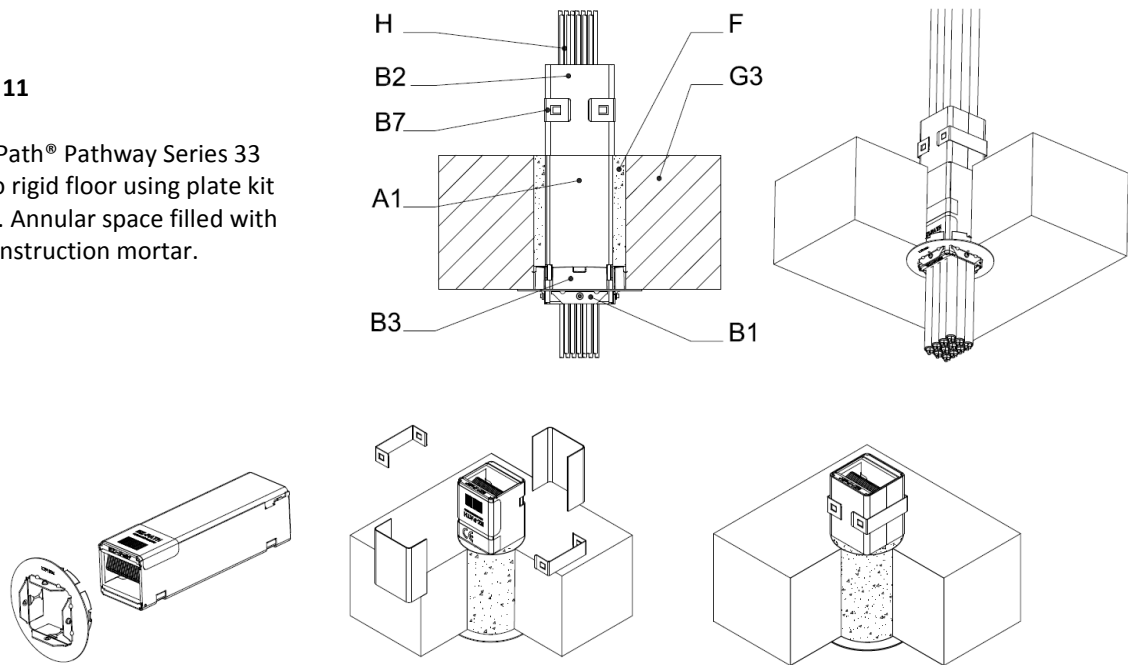

Seal Type 12

Single EZ-Path® Pathway Series 44+ secured to rigid floor using plate kit EZP144MBE. Annular space filled with regular construction mortar.

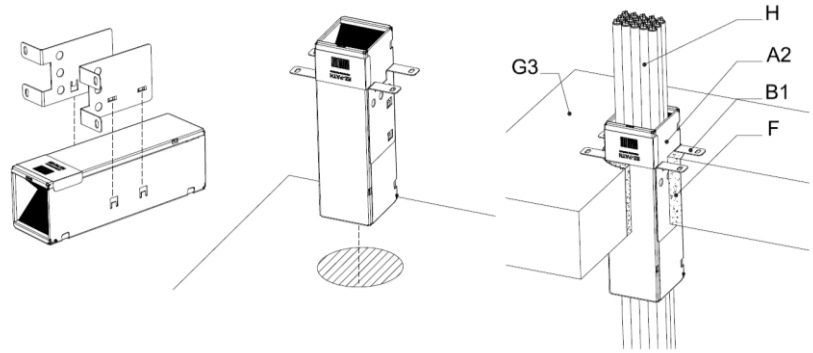

Seal Type 13

Single EZ-Path® Pathway Series 44+ secured to rigid floor using plate kit EZG144T.

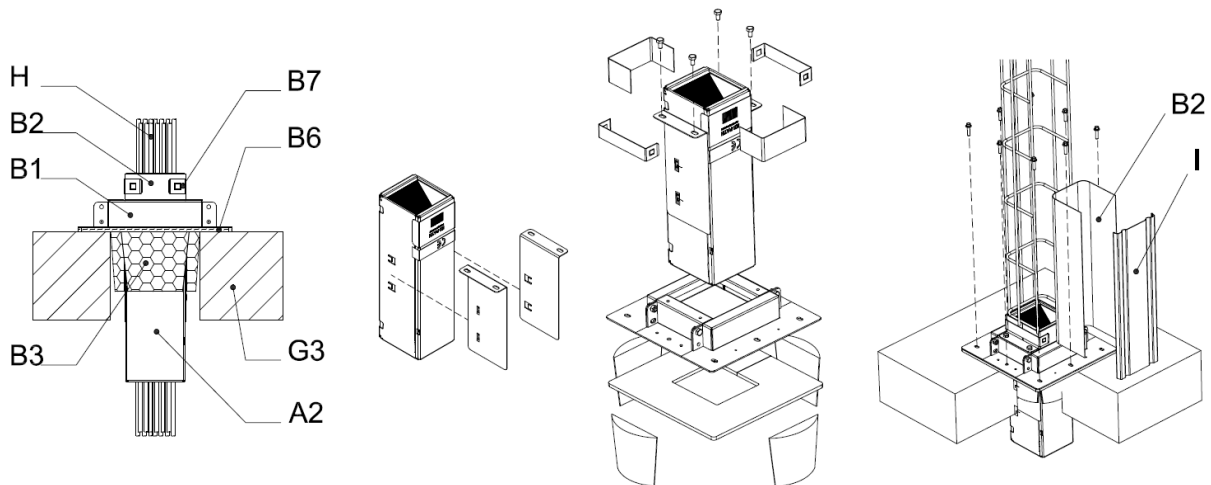

Seal Type 14

Two up to five ganged EZ-Path® Pathway Series 44+ secured to rigid floor using plate kit E郑544MBE.

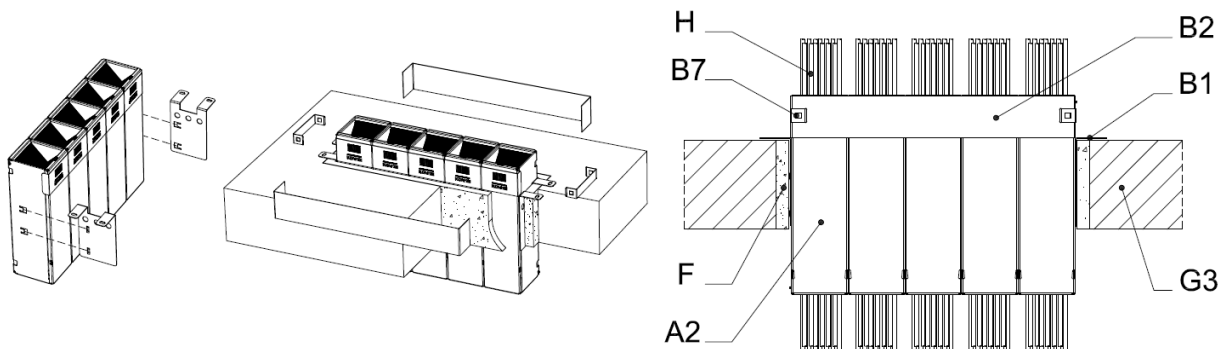

Seal Type 15

Four ganged EZ-Path® Pathway Series 44+ secured to rigid floor using plate kit EZG444T

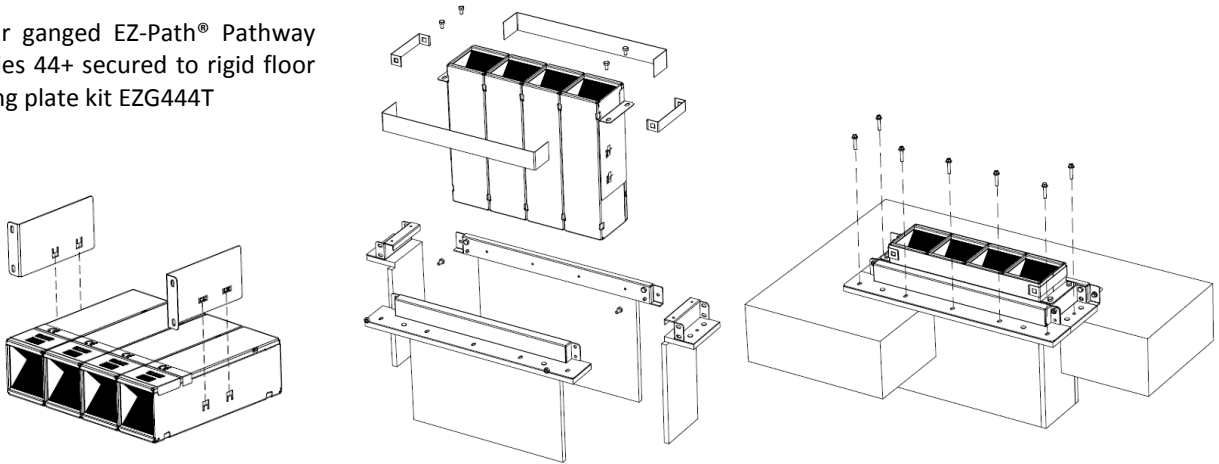

Seal Type 16

Eight ganged EZ-Path® Pathway Series 44+ secured to rigid floor using plate kit EZG844T

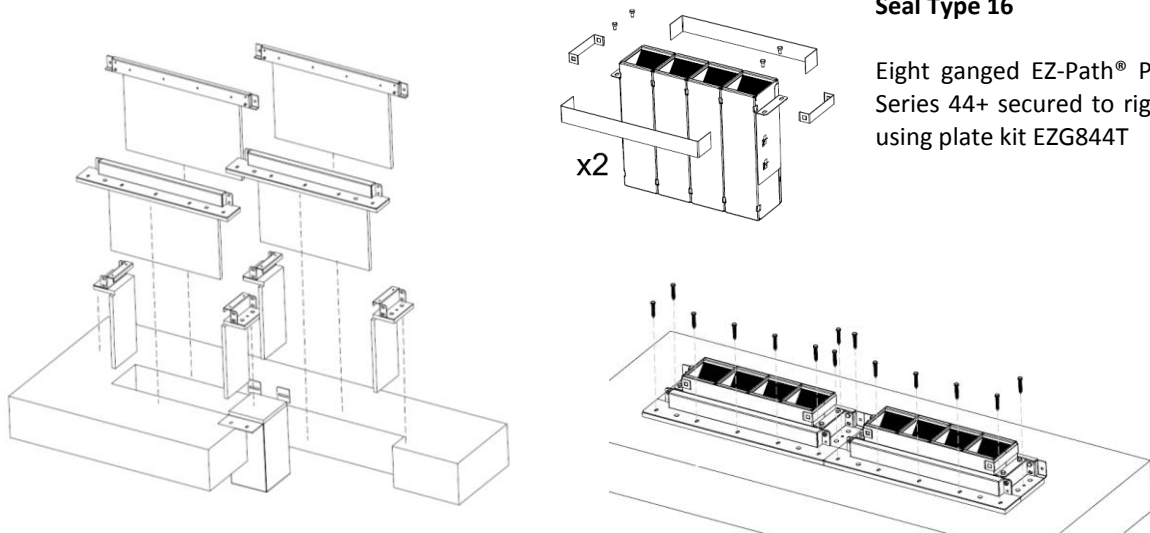

Seal Type 15 and 16

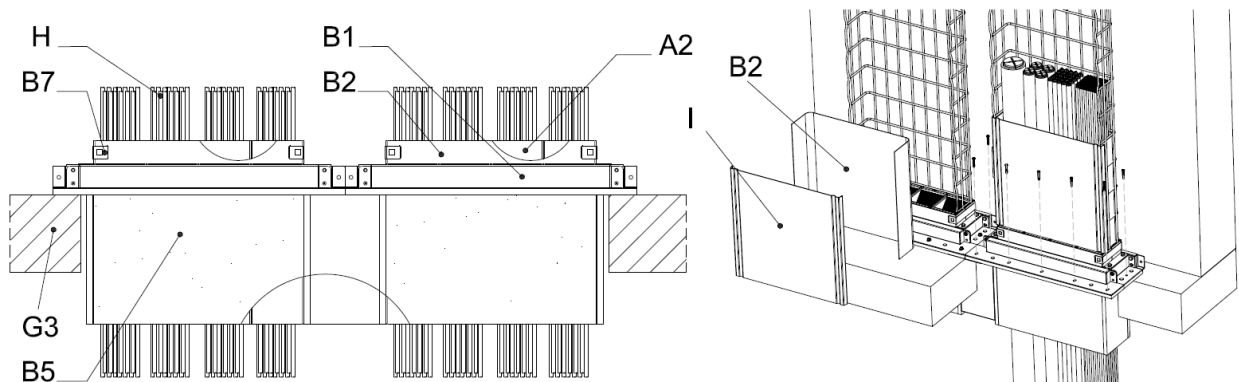

Seal Type 17

Single up to five EZ-Path® Pathways Series 44+ secured to rigid floor using plate kit E郑544MBE in association with one min 50mm thick Rockwool Firepro® Ablative Coated Batt and min 100mm thickness of Rockwool FirePro® Firestop Compound.

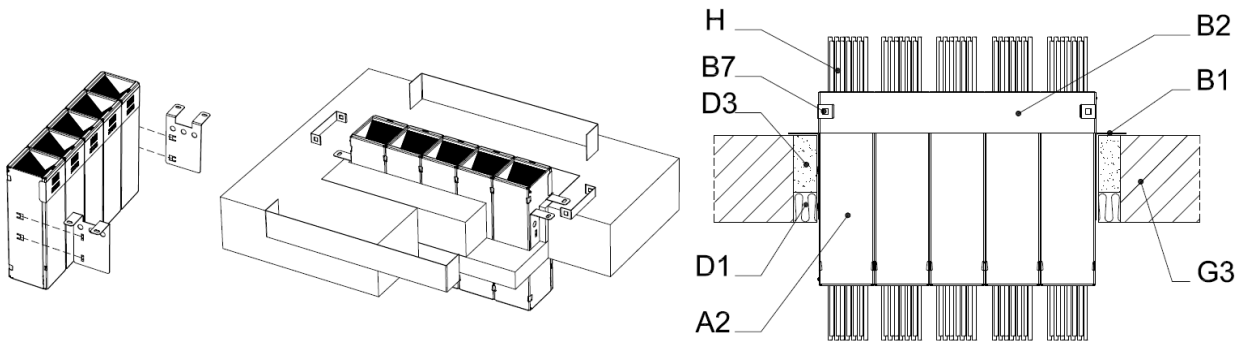

Device extension for EZ-Path® Pathways Series 33 and Series 44+

For thick barrier (wall and floor), one or more extension modules E郑33E and E郑44ES can be used to make the pathway extend from surface of the barrier. Extension is designed to insert within the pathway and to shall be attached to the top and bottom flanges.

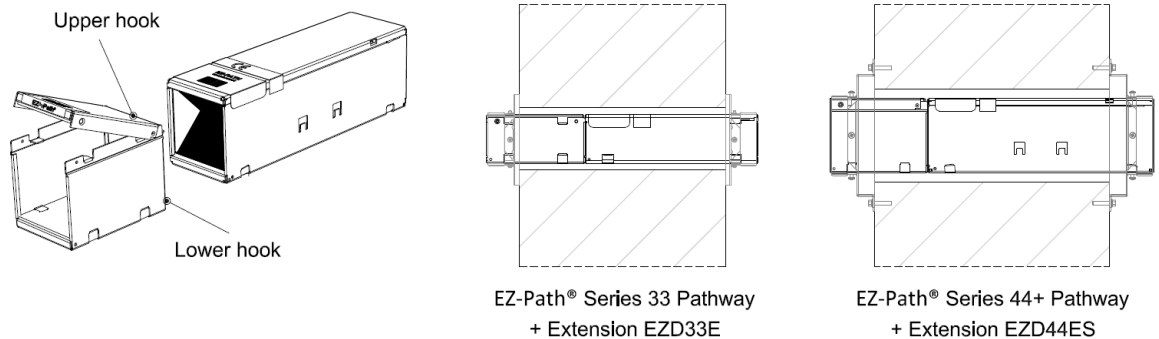

A.3 Penetration Services

Cables	Description
Small cables $\varnothing \leq 21\text{mm}$	All cable types currently and commonly used in building practice in Europe (e.g. power, control, signal, telecommunication, data, optical fibre cables, with or without cable supports).
Medium cables $\varnothing \leq 50\text{mm}$	
Large cables $\varnothing \leq 80\text{mm}$	
Cable fill	EZ-Path® Fire Rated Pathway can be used as blank (empty) up to 100% visually full of cables for all seal types.

Please refer to ANNEX “Resistance to Fire Classification” for the size of cables permitted

Tubes	Description
Tube $\varnothing \leq 16.6\text{mm}$	PVC tubes
Tube fill	EZ-Path® Fire Rated Pathway can be used as blank (empty) up to 100% visually full of conduits

Please refer to ANNEX B “Resistance to Fire Classification” for the tubes permitted

A.4 Opening sizes

A.4.1 Wall

Wall				
Seal Type	Penetration Seal	Number of EZ-Path® Pathways	EZ-Path® plate kits	Maximum opening size
1	EZ-Path® Series 33	Single Pathway	No plate (grouted devices)	Ø102 mm
		Two pathways		170 x 90 mm
2	EZ-Path® Series 33	Single Pathway	EZP133CWT	Ø102 mm
		Two Pathways	EZP233WT	155 x 81 mm
		Three Pathways	EZP333WT	230 x 81 mm
		Four Pathways	EZP433WT	305 x 81 mm
		Seven Pathways	EZP733WT	540 x 81 mm
3	EZ-Path® Series 44+	Single Pathway	No plate (grouted devices)	Ø152 - Ø155 mm
		Two Pathways		256 x 155 mm
		Three Pathways		358 x 155 mm
		Four Pathways		460 x 155 mm
		Five Pathways		562 x 155 mm
4	EZ-Path® Series 44+	Single Pathway	EZP144WE	Ø152 - Ø155 mm
5	EZ-Path® Series 44+	Single Pathway	EZP144RSE	Ø152 - Ø155 mm
6	EZ-Path® Series 44+	Single Pathway	EZP144WT	Ø152 - Ø155 mm
7	EZ-Path® Series 44+	Single Pathway	EZP544WE	105 x 118 mm
		Two Pathways		206 x 118 mm
		Three Pathways		309 x 118 mm
		Four Pathways		412 x 118 mm
		Five Pathways		515 x 118 mm
8	EZ-Path® Series 44+	Single Pathway	EZP544WT	110 x 120 mm
		Two Pathways		206 x 120 mm
		Three Pathways		309 x 120 mm
		Four Pathways		412 x 120 mm
		Five Pathways		515 x 120 mm

Wall				
Seal Type	Penetration Seal	Number of EZ-Path® Pathways	EZ-Path® plate kits	Maximum opening size
9	EZ-Path® Series 44+ + Rockwool Firepro® Ablative Coated Batts + Rockwool FirePro® Intumescent Acoustic Sealant	1 up to 5 ganged pathways	EZP544WE	568 x 800 mm
10	EZ-Path® Series 44+ + STI SpecSeal® Composite Sheet	1 up to 10 ganged pathways	EZP544WE	568 x 800 mm

A.4.2 Floor

Floor				
Seal Type	Penetration Seal	Number of EZ-Path® Pathways	EZ-Path® plate kits	Maximum opening size
11	EZ-Path® Series 33	Single pathway	EZP133KT	Ø102 mm
12	EZ-Path® Series 44+	Single pathway	EZP144MBE	Ø152 - Ø155 mm
13	EZ-Path® Series 44+	Single pathway	EZG144T	Ø152 mm
14	EZ-Path® Series 44+	Two Pathways	EZP544MBE	224 x 152 mm
		Three Pathways		338 x 152 mm
		Four Pathways		448 x 152 mm
		Five Pathways		550 x 152 mm
15	EZ-Path® Series 44+	4 ganged pathways	EZG444T	445 x 155 mm
16	EZ-Path® Series 44+	8 ganged pathways	EZG844T	1010 x 155 mm
17	EZ-Path® Series 44+ + Rockwool Firepro® Ablative Coated Batts + Rockwool FirePro® Firestop Compound	1 up to 5 ganged pathways	EZP544MBE	550 x 320 mm

ANNEX B – Resistance to Fire Classifications

B.1 EZ-Path® Fire Rated Pathway Series 33

Seal type	Number of ganged EZ-Path® Pathways 1)	Ø Cable (mm) 2)	Flexible wall		Rigid wall		
			≥ 100mm thick	≥ 122mm thick	≥ 100mm thick	≥ 122mm thick	≥ 150mm thick
1	1 up to 2 pathways	OD ≤ Ø 21	-	-	-	-	E190 / E120 3)
2	1 pathway with EZP133CWT kit	OD ≤ Ø 21	EI60 / E120 4)	EI120	EI60 / E120 4)	EI120	EI120 / E240 3)
		OD ≤ Ø 50	-	-	-	-	EI60 / E240 3)
	2 up to 7 pathways	OD ≤ Ø 21	-	EI120	-	EI120	EI120 / E240 3)
		OD ≤ Ø 50	-	-	-	-	EI60 / E240 3)

Seal type	Number of ganged EZ-Path® Pathways 1)	Ø Cable mm 2)	Rigid floor ≥ 150mm thick
11	1 pathway with EZP133KT plate kit	OD ≤ Ø 21 Telecommunication cables only	EI180 / E240 3)
		OD ≤ Ø 21	EI120 / E240 3)

1) EZ-Path® systems can be installed as blank device (empty) up to 100% fill of cables

2) Maximum outside diameter for all sheathed cables

3) Requires annular space of opening to be filled with regular construction mortar.

For the seal type 2, when mortar is installed, the system achieves an integrity performance of E240. When no mortar is installed with the seal type 2, integrity is E120

4) In min 100mm thick wall, annular space filled with min. 45 kg/m³ stone wool for Ø102mm circular opening

B.2 EZ-Path® Fire Rated Pathway Series 44+ in flexible and rigid wall

Seal type	Number of ganged EZ-Path® Pathways 1)	Ø Cable (mm) 2)	Flexible wall		Rigid wall		
			≥ 100mm thick	≥ 122mm thick	≥ 100mm thick	≥ 122mm thick	≥ 150mm thick
3	1 pathway grouted	OD ≤ Ø 21	-	-	EI90 / E240 3) 7)		EI120 / E240 3) 7)
	2 up to 5 pathways grouted	OD ≤ Ø 21	-	-	EI90 / E240 3) 7)		
4	1 pathway with EZP144WE kit	OD ≤ Ø 21	EI90 / E120 7)		EI90 / E120 7) 8)		EI120 6) 7) 8)
5	1 pathway with EZP144RSE kit	OD ≤ Ø 21	EI90 / E120 7)		EI90 / E120 7) 8)		EI120 6) 7) 8)
6	1 pathway with EZP144WT kit	OD ≤ Ø 21	-	EI120	-	EI120 8)	EI120 / EI180 8)
		OD ≤ Ø 80	-	EI120 5)	-	EI120 5)	EI120 / EI180 5)
7	1 up to 5 pathways with EZP544WE kit	OD ≤ Ø 21	EI120 7)		EI120 7) 8)		
8	1 up to 5 pathways with EZP544WT kit	OD ≤ Ø 21	-	EI120	-	EI120 8)	EI120 / EI180 8)
		OD ≤ Ø 80	-	EI120 5)	-	EI120 5)	EI120 / EI180 5)
9	1 up to 5 pathways with EZP144WE kit + Rockwool Firepro® Ablative Coated Batts + Rockwool FirePro® Intumescent Acoustic Sealant	OD ≤ Ø 21	EI90 / E120				
10	1 up to 5 pathways + STI SpecSeal® Composite Sheet	OD ≤ Ø 21	EI60 / E120 Opening to be max 568 x 800mm. Cavity fill to full depth with min 100 kg/m ³ mineral wool batt insulation				
	1 up to 10 pathways + STI SpecSeal® Composite Sheet		EI60 / E120 Opening to be max 568 x 700mm. Cavity fill to full depth with min 45 kg/m ³ mineral wool batt insulation				

1) EZ-Path® systems can be installed as blank device (empty) up to 100% fill of cables

2) Maximum outside diameter for all sheathed cables

3) Requires annular space of opening to be filled with regular construction mortar

5) Requires cable tray in association with cable tray cover and intumescent paper sheet to be installed on both sides of wall

6) When Telecommunication cables OD ≤ Ø 21 are used, the seal types 5 and 6 achieve a resistance to fire of EI120. For all sheathed cables OD ≤ Ø 21, the seal types 5 and 6 achieve a resistance to fire of E90/EI120.

7) 16.6 mm Ø PVC tubes can be installed in EZ-Path® in association with cables of OD ≤ Ø 21

8) When annular space is filled with regular construction mortar, integrity of the system is E240

B.3 EZ-Path® Fire Rated Pathway Series 44+ in rigid floor

Seal type	Number of ganged EZ-Path® Pathways 1)	Ø Cable mm 2)	Rigid floor ≥ 150mm thick
12	1 pathway with EZP144MBE kit	OD ≤ Ø 21	EI120 3) 7)
13	1 pathway with EZG144T kit	OD ≤ Ø 21	EI180 5)
		OD ≤ Ø 50	EI120 / EI180 5)
		OD ≤ Ø 80	EI90 / EI180 5)
14	2 up to 5 pathways with EZP544MBE kit	OD ≤ Ø 21	EI120 3) 7)
15	4 pathways with EZG444T kit	OD ≤ Ø 21	EI180 5)
16	and 8 pathways with EZG844T kit	OD ≤ Ø 80	EI120 / EI180 5)
17	1 up to 5 pathways with EZP544MBE kit + Rockwool Firepro® Ablative Coated Batts + Rockwool FirePro® Firestop Compound	OD ≤ Ø 21	EI120

1) EZ-Path® systems can be installed as blank device (empty) up to 100% fill of cables

2) Maximum outside diameter for all sheathed cables

3) Requires annular space of opening to be filled with regular construction mortar

5) Requires cable tray in association with cable tray cover and intumescent paper sheet to be installed on both sides of wall

7) 16.6 mm Ø PVC tubes can be installed in EZ-Path® in association with cables of OD ≤ Ø 21